



HYUNDAI

Номер
аксессуара:

10.3656.12

Наименование продукта:
Фаркоп несъемный

Инструкция по установке



 **HYUNDAI**

Дата
10/2016

Номер аксессуара:

10.3656.12



Модель автомобиля: Creta

Год выпуска автомобиля: 2016-

Допустимая полная масса прицепа: 1300 kg

Вертикальная нагрузка на шар: 50 kg



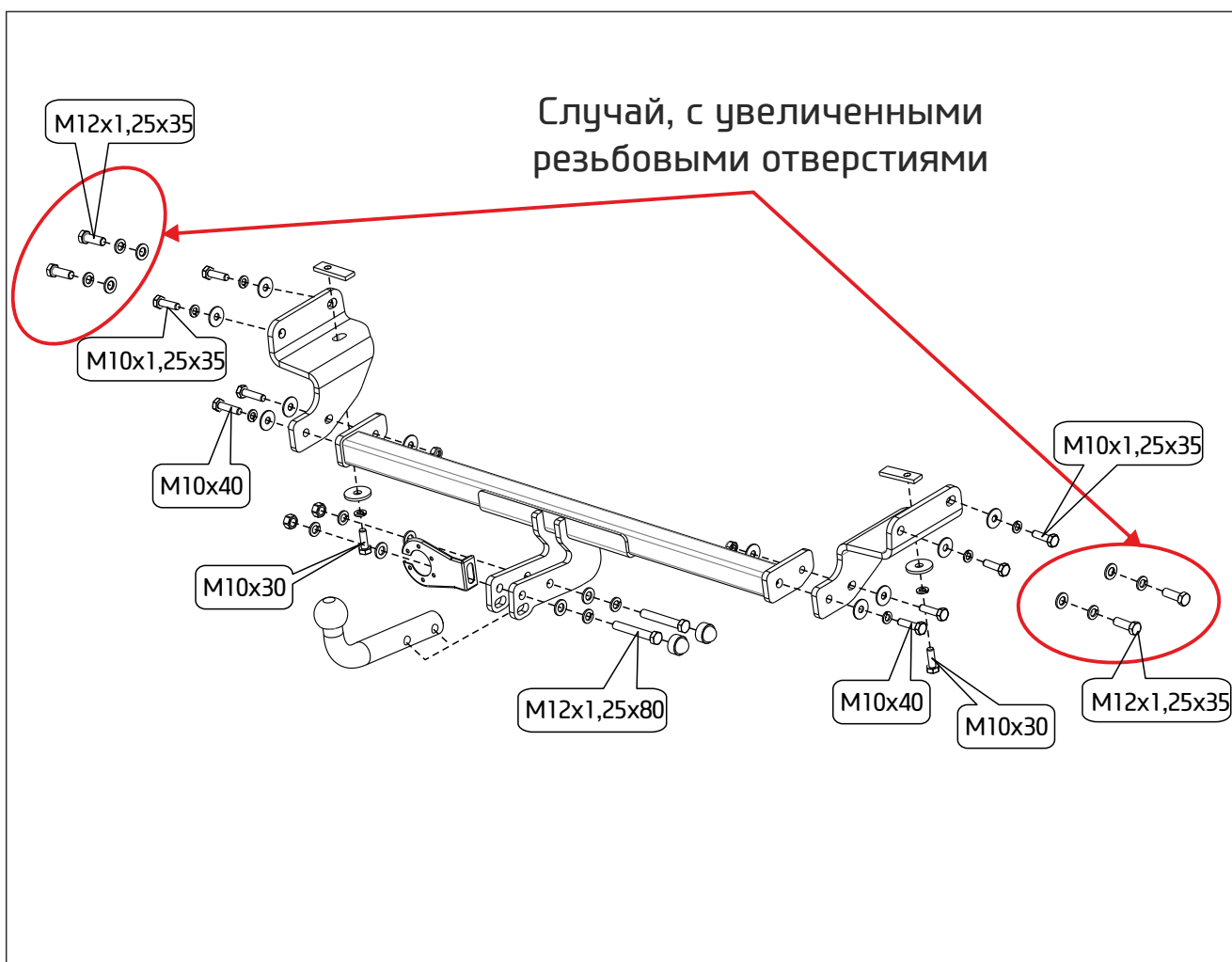



Вес нетто: 15,37 kg

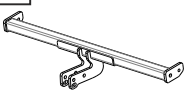
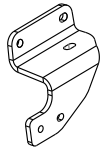
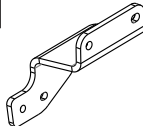
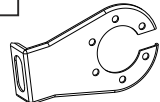
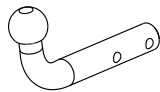

Номер аксессуара:

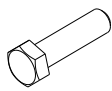
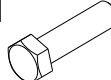
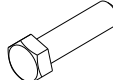
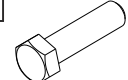
10.3656.12

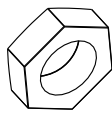
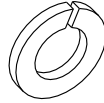
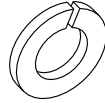
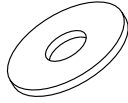
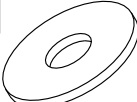
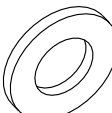

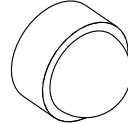
| | | | | |
|--|--|--|---|---|
| A  x1 | B  x1 | C  x1 | D  x1 | E  x1 |
| F1  M10x1,25x35 x4 | F2  M12x1,25x35 x4 | F3  M12x1,25x80 x2 | F4  M10x30 x2 | F5  M10x40 x4 |
| G1  M10 x2 | G2  M12x1,25 x2 | H1  Ø10G x8 | H2  Ø12G x8 | I1  Ø10 x10 |
| I2  НД 7001 x2 | J  Ø12 x8 | K  НД 3003 x2 | L  x2 | |

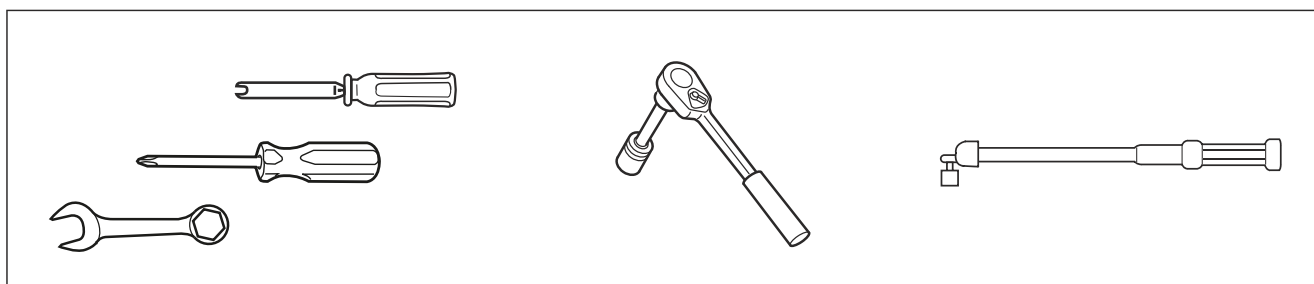

(RU) Прежде чем начать установку, прочитайте данную инструкцию. Гарантия на продукцию предоставляется только в случае установки официальным дилером HYUNDAI.

Номер аксессуара:

10.3656.12

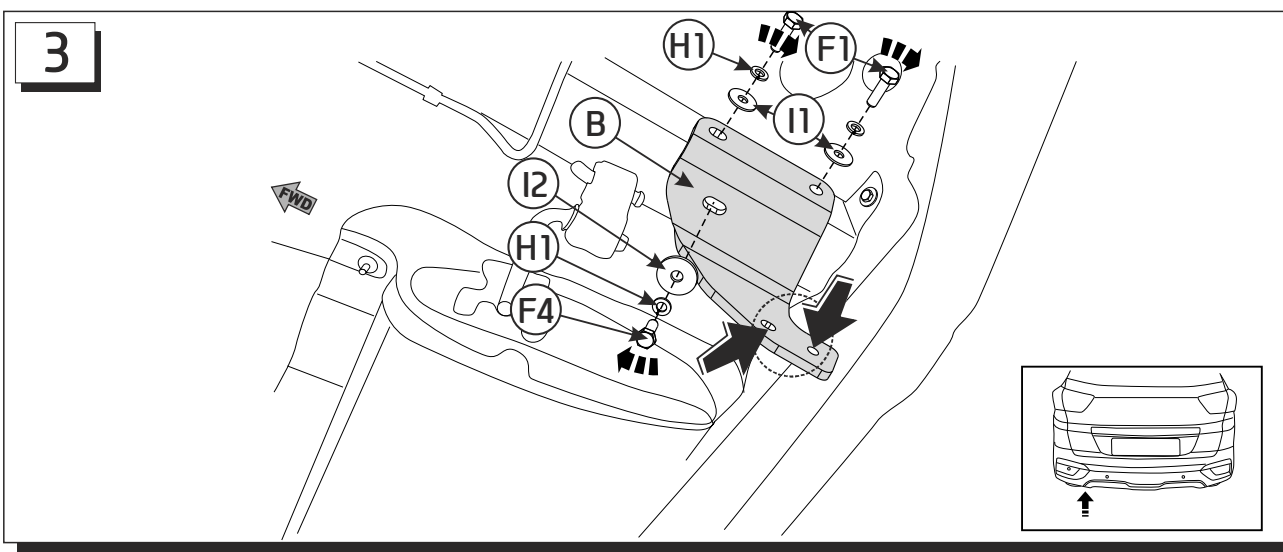
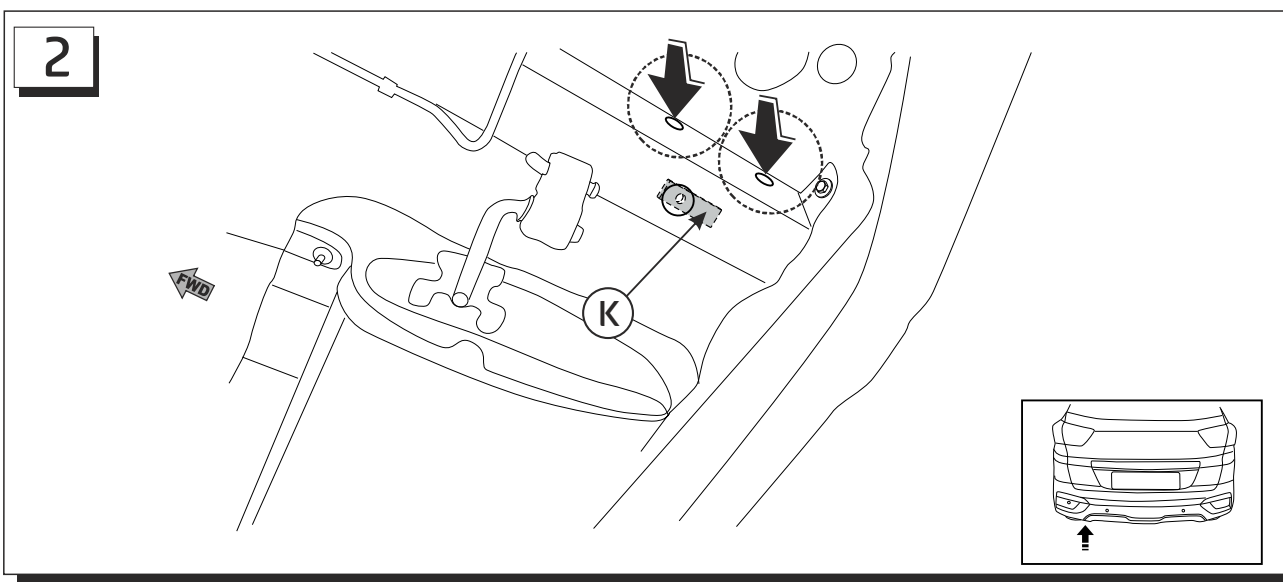
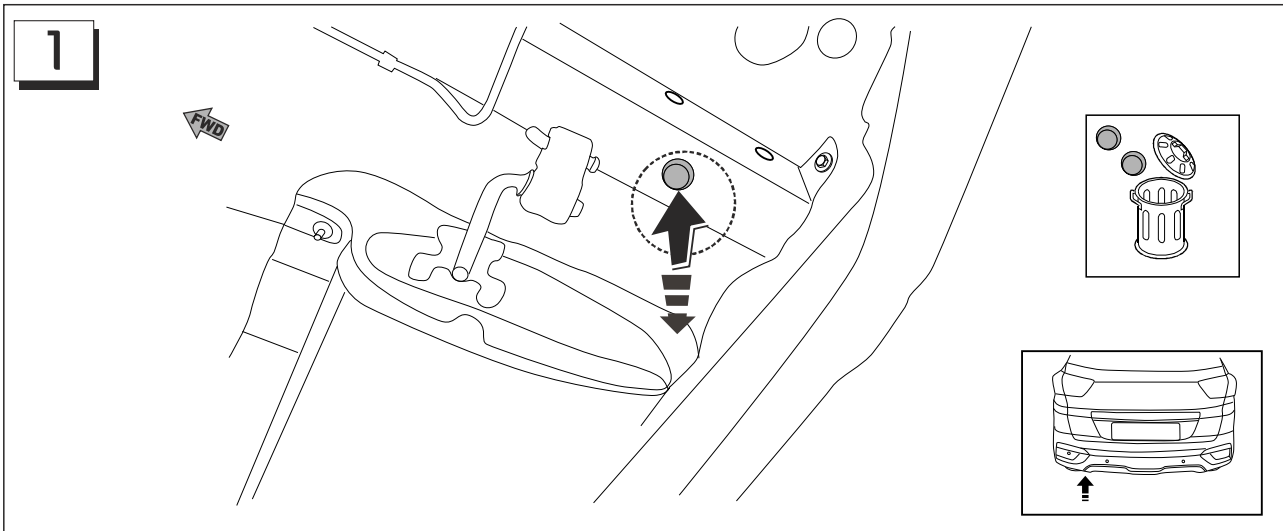

Номер аксессуара:

10.3656.12



4

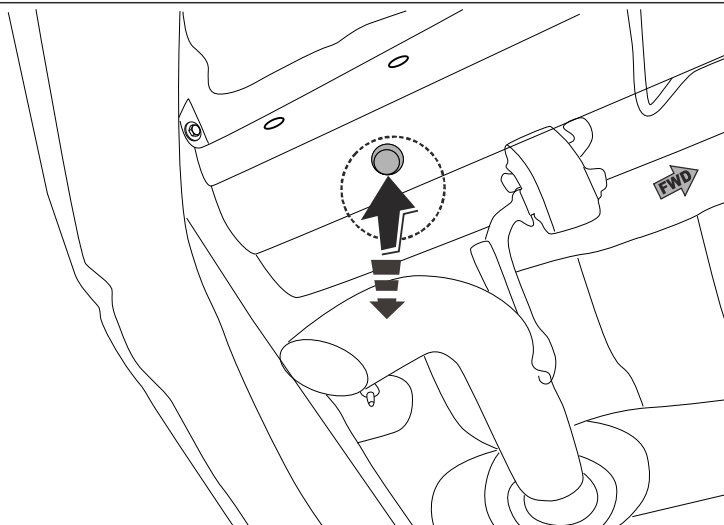
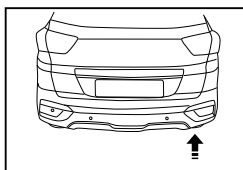
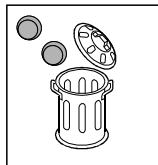

5

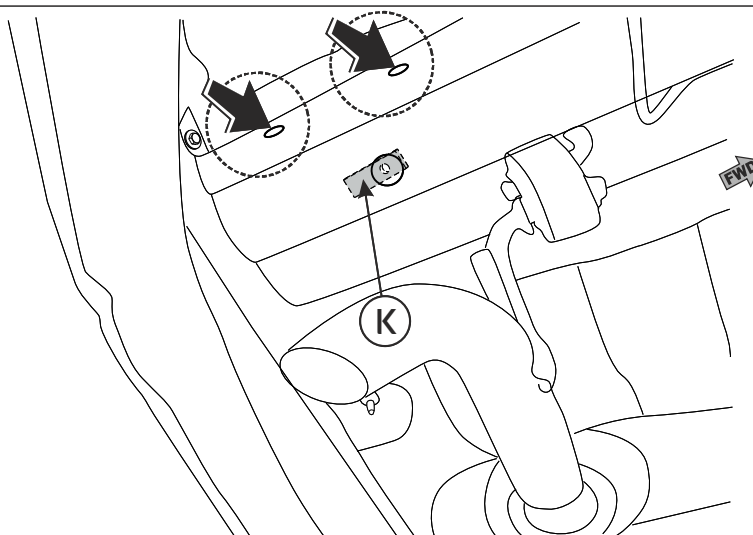
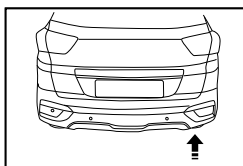

6

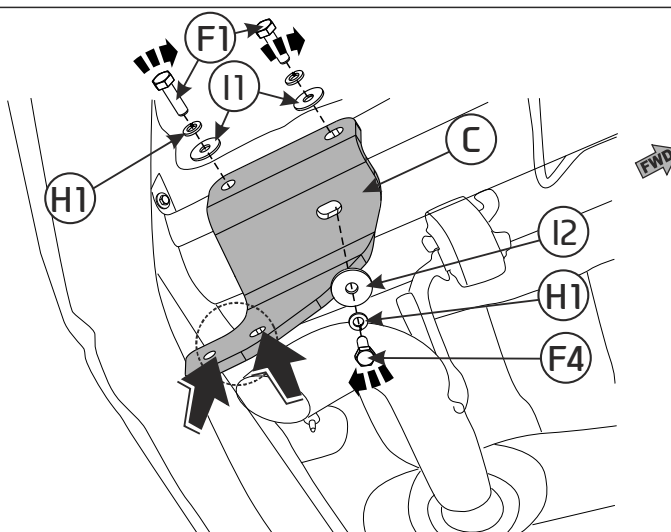
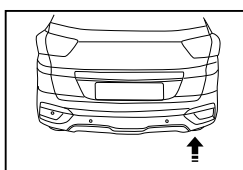

Номер аксессуара:

10.3656.12



7

Установить штангу, соединив с левым и правым кронштейнами

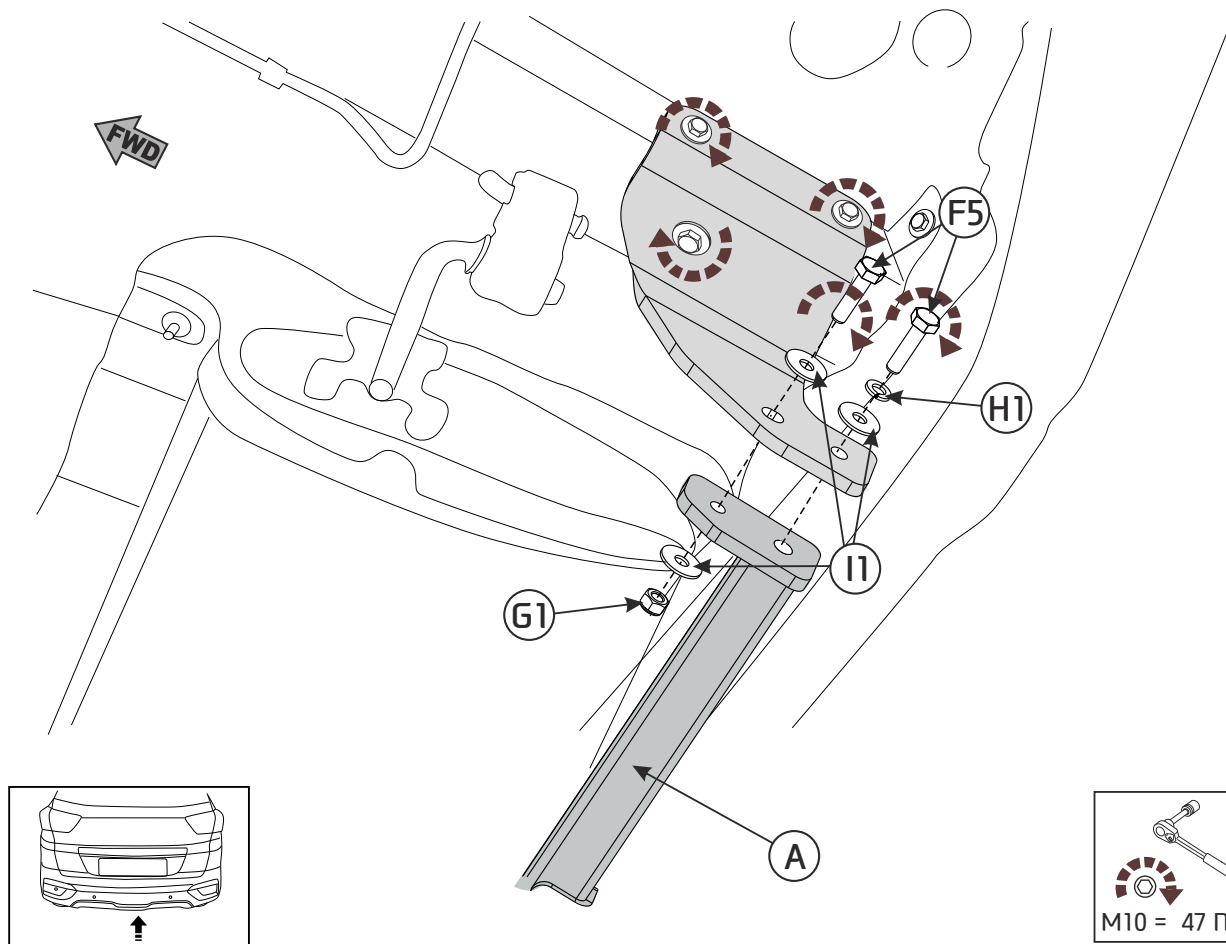

8

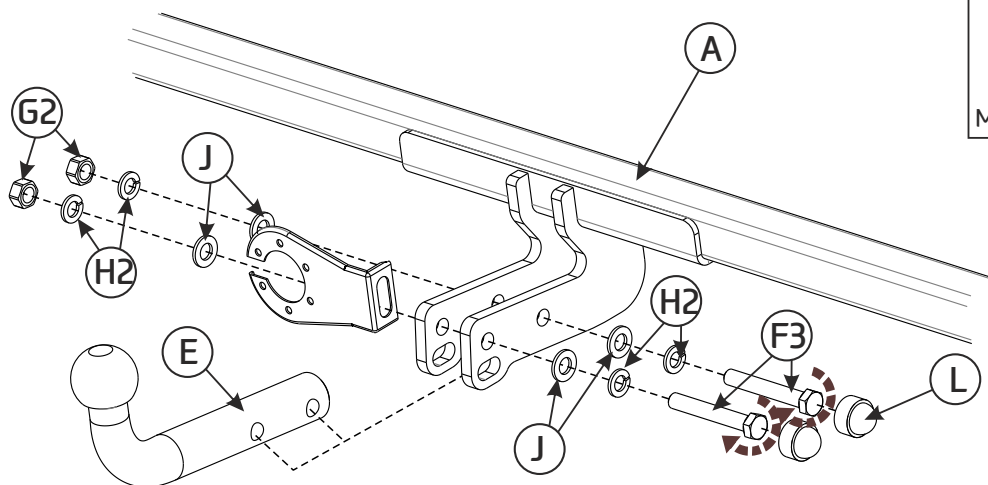

Номер аксессуара:

10.3656.12



9

